

ENGINEERING
YOUR SPRAY SOLUTION



FT 90-03 POM

JKI ANERKENNUNGEN

FT 90-03 POM - JKI ANERKENNUNGEN

G-Nummer

- FT 90-03 POM – G2086

Anwendungen:

- Band Applikationen in Reihenkulturen:
 - Band-, Hack- und Kastenspritzgeräten
 - Furchenbehandlung in Kartoffellegegeräten
 - Reihen- oder Zwischenreihenbehandlung mit Feldspritzgeräten
 - Dropleg^{UL} – Anwendungen im Bestand
 - Rückenspritzen
- Dropleg^{UL} – Anwendungen unterhalb der Blühebene in Raps



FT 90-03 POM - JKI ANERKENNUNGEN

Anwendungsbestimmungen

ENGINEERING
YOUR SPRAY SOLUTION



Band Applikationen in Reihenkulturen

- **90%** Abdriftreduktion von 1 – 4 bar
- Spritzdruck: 1 – 4 bar
- Empfohlene Spritzbandbreite über den Spritzabstand zur Zielfläche einstellen

Spritzhöhe (cm)	Spritzbandbreite (cm)
10	25
20	50
30	65
40	80

FT 90-03 POM - JKI ANERKENNUNGEN

Anwendungsbestimmungen

Dropleg^{UL} – Anwendungen unterhalb der Blühebene in Raps

- Abdriftreduktion **90%** bei 1,6 bar
- Spritzdruck: 1 – 6 bar
- Dropleg^{UL}-Abstand 0,5 m
- Düseneinstellung 2 x 90° = 180° abwärtsgerichtet
- Eindringtiefe in den Bestand = Blühebene Raps

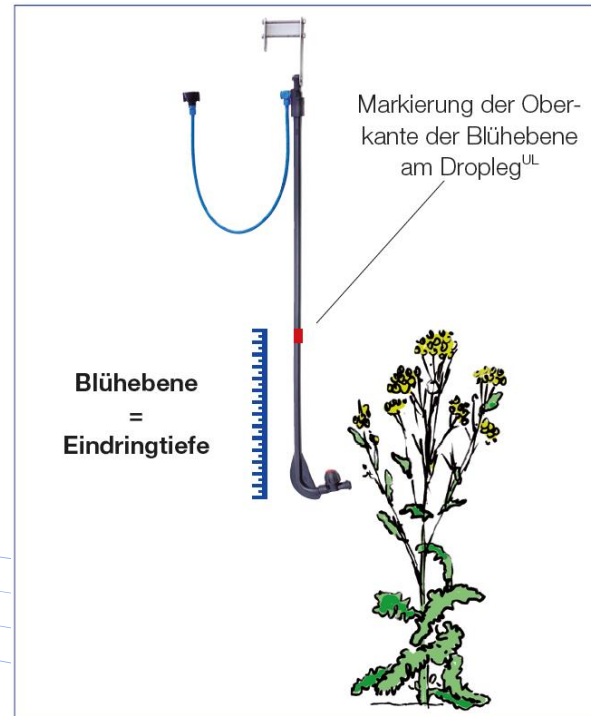
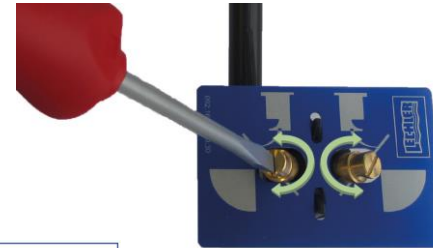

FT 90 – TECHNISCHE MERKMALE

Zungendüse

- Flachstrahldüse mit rechteckförmiger Flüssigkeitsverteilung
- Kompakte Bauweise
- Strahlaufbau bereits ab 1 bar
- Verstopfungsunanfällig bedingt durch große und runde Fließquerschnitte
- Freispülen der Prallflächen bei Verunreinigungen
- Besonders abdriftarm dank Vorzerstäuber



Düsengrößen
01 – 05



Spritzwinkel
90°



Werkstoffe
POM, Edelstahl



Druckbereiche
– FT 90: 1 – 3 – 6 bar



Empfohlene Filter
80 M 01
60 M 015 – 04
25 M 05 – 20



Tropfengrößen
FT 90:
Extrem grob – fein



Überwurfmutter
Ø 12,65 mm



Spritzhöhen
– Flächenanwendung
60 – 75 – 90 cm
– Bandanwendung
10 – 40 cm

Anwendungsbereiche



Pflanzenschutzmittel
und Wachstums-
regulatoren



Rückenspritzen



Dropleg^{UL}



Gewächshaus



Bandspritzung
FT 90

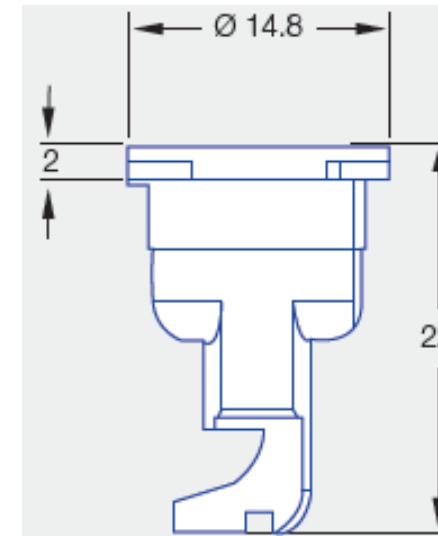
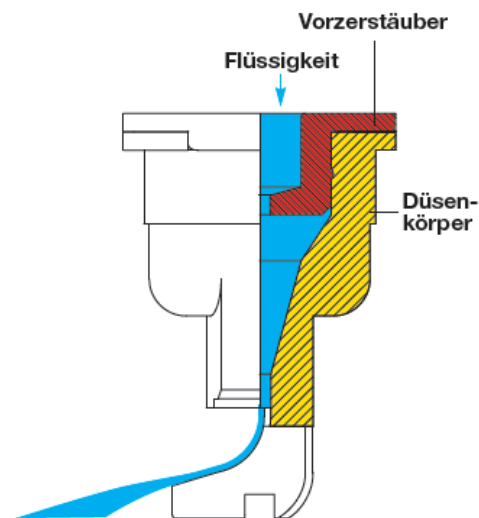

FT 90 – TECHNISCHE MERKMALE

Spritztable und Filterempfehlungen

 ()	ISO 25358			l/min	l/ha						l/ha					
	FT 90	FT 140			6.0 km/h	8.0 km/h	10.0 km/h	12.0 km/h	14.0 km/h	16.0 km/h	6.0 km/h	8.0 km/h	10.0 km/h	12.0 km/h	14.0 km/h	16.0 km/h
FT 90-01 140-01 (80 M)	XC		1	0.23	46	35	28	23	20	17	31	23	18	15	13	12
	C	VC	2	0.32	64	48	38	32	27	24	43	32	26	21	18	16
	M	C	3	0.39	78	59	47	39	33	29	52	39	31	26	22	20
	M		4	0.45	90	68	54	45	39	34	60	45	36	30	26	23
	F		6	0.55	110	83	66	55	47	41	73	55	44	37	31	28
FT 90-015 140-015 (60 M)	XC	VC	1	0.34	68	51	41	34	29	26	45	34	27	23	19	17
	M	M	2	0.48	96	72	58	48	41	36	64	48	38	32	27	24
	M	F	3	0.59	118	89	71	59	51	44	79	59	47	39	34	30
	M		4	0.68	136	102	82	68	58	51	91	68	54	45	39	34
	F		6	0.83	166	125	100	83	71	62	111	83	66	55	47	42
FT 90-02 140-02 (60 M)	VC	VC	1	0.46	92	69	55	46	39	35	61	46	37	31	26	23
	M	F	2	0.65	130	98	78	65	56	49	87	65	52	43	37	33
	M	F	3	0.80	160	120	96	80	69	60	107	80	64	53	46	40
	M		4	0.92	184	138	110	92	79	69	123	92	74	61	53	46
	F		6	1.13	226	170	136	113	97	85	151	113	90	75	65	57
FT 90-03 140-03 (60 M)	VC	C	1	0.69	138	104	83	69	59	52	92	69	55	46	39	35
	M	F	2	0.97	194	146	116	97	83	73	129	97	78	65	55	49
	M	F	3	1.19	238	179	143	119	102	89	159	119	95	79	68	60
	M		4	1.37	274	206	164	137	117	103	183	137	110	91	78	69
	F		6	1.68	336	252	202	168	144	126	224	168	134	112	96	84
FT 90-04 140-04 (60 M)	VC	M	1	0.91	182	137	109	91	78	68	121	91	73	61	52	46
	C	F	2	1.29	258	194	155	129	111	97	172	129	103	86	74	65
	M	M	3	1.58	316	237	190	158	135	119	211	158	126	105	90	79
	M		4	1.82	364	273	218	182	156	137	243	182	146	121	104	91
	F		6	2.23	446	335	268	223	191	167	297	223	178	149	127	112
FT 90-05 140-05 (25 M)	VC	M	1	1.14	228	171	137	114	98	86	152	114	91	76	65	57
	C	F	2	1.61	322	242	193	161	138	121	215	161	129	107	92	81
	C	M	3	1.97	394	296	236	197	169	148	263	197	158	131	113	99
	M		4	2.27	454	341	272	227	195	170	303	227	182	151	130	114
	F		6	2.79	558	419	335	279	239	209	372	279	223	186	159	140

LECHLER DÜSENKALKULATOR

Bandspritzung and Dropleg^{UL} Anwendungen

ENGINEERING
YOUR SPRAY SOLUTION



Lechler App als nützliche Arbeitshilfe

- Bandspritzung
- Dropleg^{UL} Anwendungen
- Berechnung
 - Düsengröße
 - Spritzdruck
 - l / ha auf behandelter Fläche

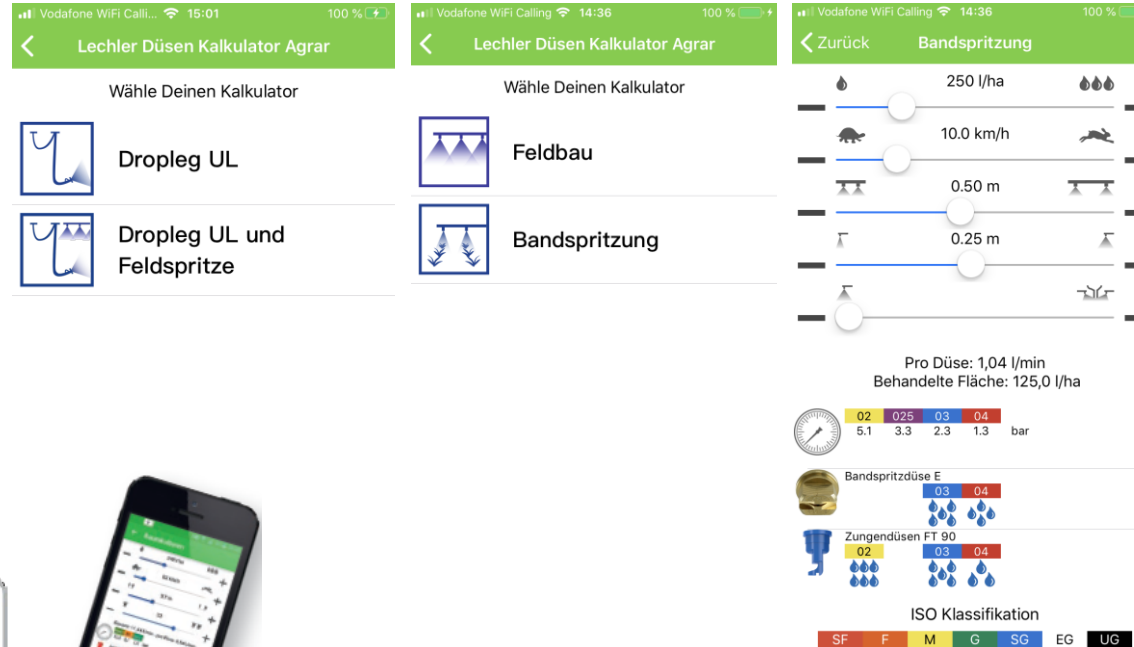

Kostenloser Download



Apple



Android

Düsen-Kalkulator-App

ENGINEERING
YOUR SPRAY SOLUTION

